



**Sky**  
Elevator  
[www.sky-elevator.com](http://www.sky-elevator.com)

# Sky-207



Bi-directional Overspeed  
Governor  
Mounting, operating and  
maintenance Manuel

## **INDEX**

<b>1- GENERAL INFORMATION</b>	<b>18</b>
<b>1.1 EXPLANATIONS AND WORKING REGULATIONS</b>	<b>18</b>
<b>1.2 SAFETY PRECAUTIONS</b>	<b>21</b>
<b>1.3 WORKING INSTRUCTIONS ON SAFETY STRUCTURAL</b>	<b>21</b>
<b>1.4 CHECK UPON RECEIPT</b>	<b>22</b>
<b>1.5 LIST OF PARTS</b>	<b>22</b>
<b>2.ASSEMBLY</b>	<b>23</b>
<b>2.1 ASSEMBLY OF THE OVERSPEED GOVERNOR ON THE FLOOR</b>	<b>23</b>
<b>2.1.1 ASSEMBLY IN THE ENGINE ROOM</b>	<b>23</b>
<b>2.1.2 ASSEMBLY STEPS</b>	<b>24</b>
<b>2.2 ASSEMBLY OF THE ROPE OF THE OVERSPEED GOVERNOR AND TENSION PULLEY</b>	<b>24</b>
<b>2.3 ASSEMBLY OF THE SAFETY SWITCHES</b>	<b>26</b>
<b>3.OPERATION TESTING</b>	<b>26</b>
<b>4.WARRANTY REGULATIONS and RESPONSIBILITY</b>	<b>27</b>
<b>5.MAINTENANCE</b>	<b>27</b>

	ASRG 1.0 Overspeed Governor Technical Data	ASRG 1.6 Overspeed Governor Technical Data
Min Adjustable Nominal Speed	0,4 m/s	0,63 m/s
Nominal Çalışma Hızı (min)		
Max Adjustable Nominal Speed	1,0 m/s	1,6 m/s
Nominal Çalışma Hızı (max)		
Bearings	From two sides ball bearings	From two sides ball bearings
Yataklar	Çift rulmanlı	Çift rulmanlı
Direction	Up and down	Up and down
Çalışma Yönü	Yukarı aşağı	Yukarı aşağı
Tensioning Weight	25 kg	25 kg
Gergi Ağırlığı		
Rope Diameter	6 - 8 mm	6 - 8 mm
Halat Çapı		
Governor Pulley Diameter	230 mm	320 mm
Kasnak Çapı		
Safety Gear Type	use with progressive safety gears only	use with progressive safety gears only
Fren Bloku Tipi	Kaymalı fren bloğu ile kullanılmalıdır.	Kaymalı fren bloğu ile kullanılmalıdır.



## 1-GENERAL INFORMATION

### 1.1 EXPLANATIONS AND WORKING REGULATIONS

The overspeed governor is a safety device which activates when the nominal speed of elevator car is exceeded 15 %. If the elevator car, during its upward & downward exceeds the nominal speed, upon reaching the release speed set by the manufacturer the governor wheel is blocked and the governor rope is wedged by means of a sheave groove made in form of a key groove. This action activates the safety gears. The cabinet stops and comes to a standstill on the guides.

The main part of pulley is shown below. Fig. 1

- Governor pulley-(1), with trapezoidal undercut groove to house the overspeed governor
- Rope test grooves for operation tests-(2)
- Cam rim (3)
- Eccentric stops- figure (4)

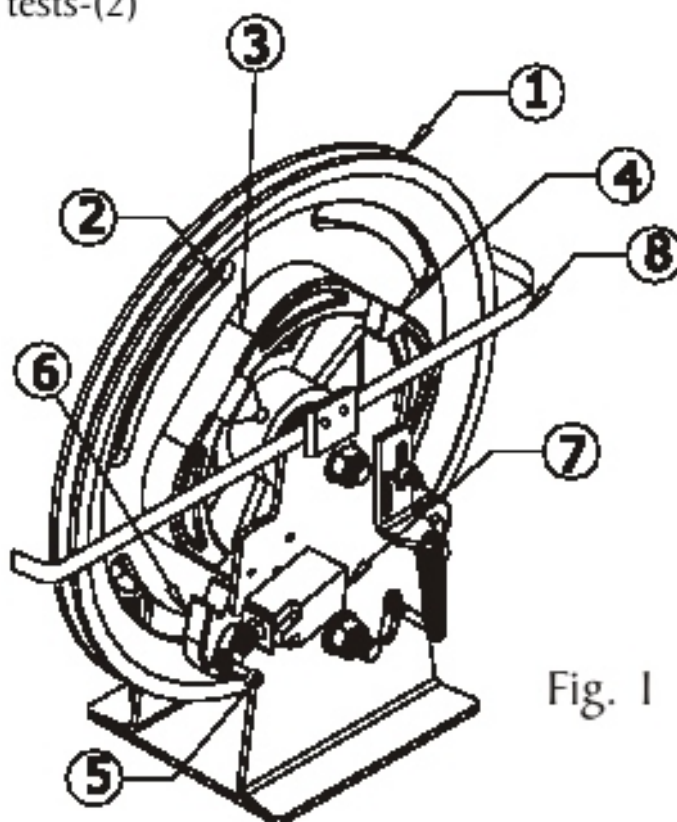

Fig. 1

The rope, secured to the clamp of the safety gear and stretched by a weight, operates the governor pulley through its own pressure in the trapezoidal undercut groove (1).

The square shaped path (3), which is on the sheave (1) moves the catch pendulum (6) slightly up and down. The catch pendulum is forced to move on the path by a spring.

When the centrifugal force exceeds the spring force, the catch pendulum contacts on the catch cam (4). And the sheave (1) is blocked. Before braking the switch is activated and the safety circuit of the plant is switched off. The rope protection hook (8) prevents the rope to come out from the groove.

The overspeed governor is provided with the homologation according to the rules and regulations for elevators 95/16/CE and TS 10922/en 81-1, EN 81-2.

## DISPOSITION ON THE TOP OF THE ELEVATOR SHAFT.

For the assembly on the top of the elevator shaft, the overspeed governor must be easily accessible from the outside (e.g. through a maintenance door.)

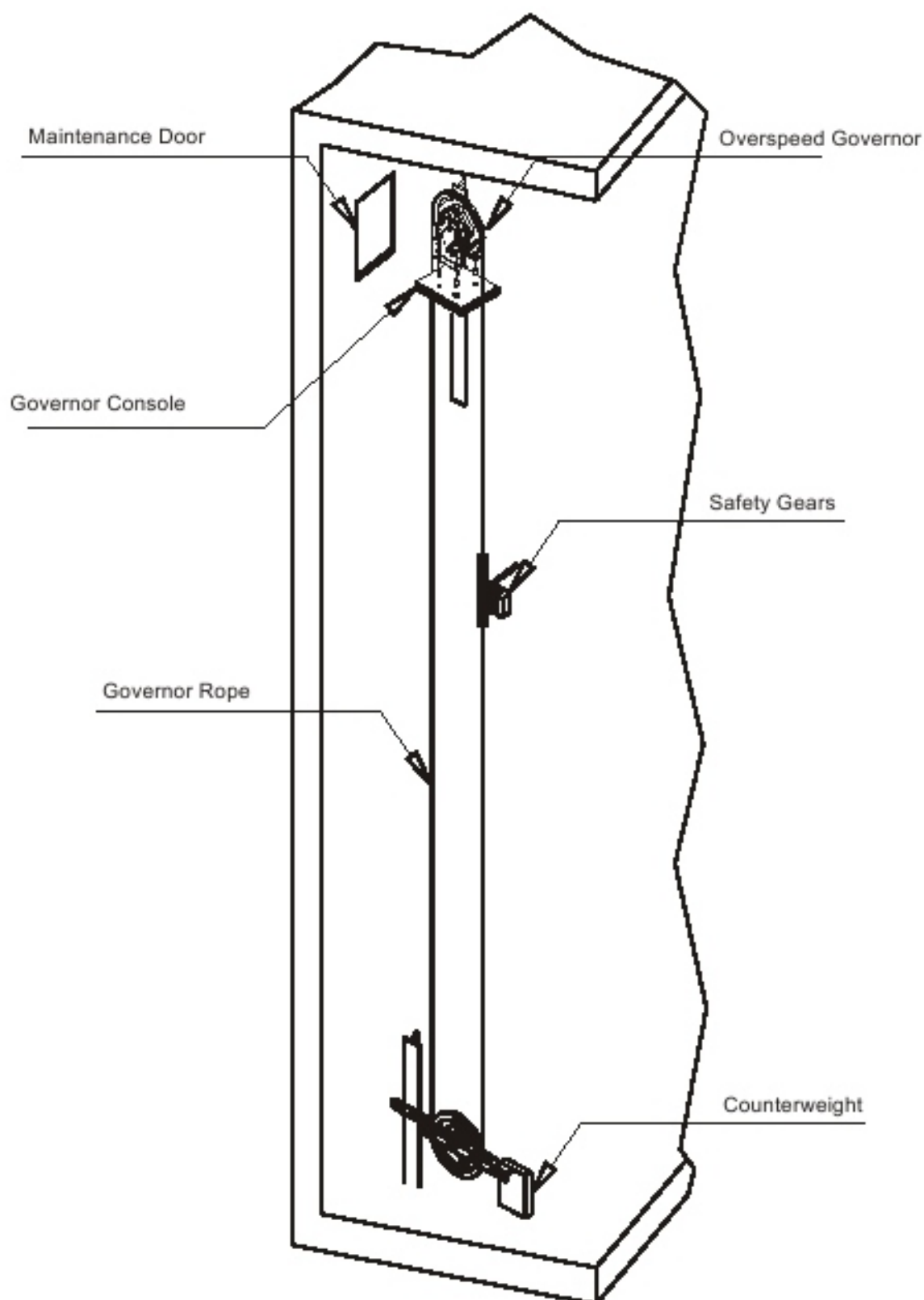

## DISPOSITION IN THE ENGINE ROOM.

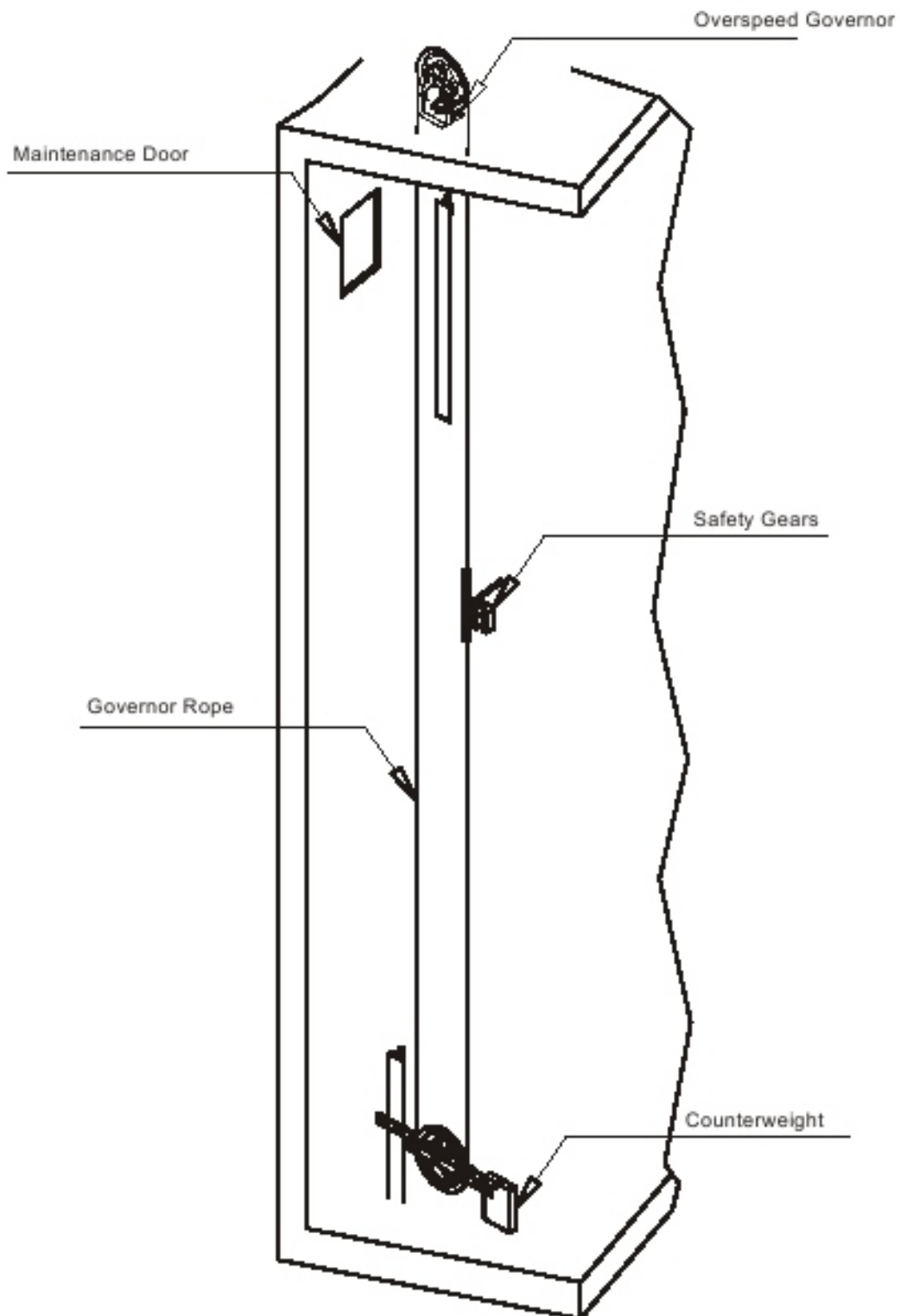

This guide must be kept near oversped governor .ASRG 10 and ASRG 16 must be used only to activate prograssive safety gears. Usage with instantenaous safety gears does not compiles with EN-81



Assembly must be done by a person who are well acquainted with the assembly of elevators. ASPAR Asansör A.Ş declines any responsibility that have not been carried out according to this guide. User should accept only sealed overpeed governor. During the transportation ,the overspeed governor can be damaged. Never use damaged products.

Beacuse of the technical safety rules the following situations would never happen ;  
A-For elevator use only. Manufacturer is not responsible for the products that is not used on purpose.

b-Choose the product according to the declared speed.

c-Spare part changes are not acceptable on overspeed governor.

## 1.2 SAFETY PRECAUTIONS

The Assembler company is responsible for the safety of the work. They should consider warnings in the guide.



**WARNING!** Indication of danger of possible damages to structural elements and its component parts. May be cause for injuries and serious product damages.



**DANGER!** This symbol shows that health and lives of related persons are under risk. Always pay attention to warnings



Indication of useful information

These instructions are an integral part of this guide it must be kept in an easily accessible place like in the engine room.

## 1.3 WORKING INSTRUCTIONS ON SAFETY STRUCTURAL ELEMENTS

Overspeed governors belong to safety structural elemnts group. It is absolutely necessary to observe the rules and regulations that refer to structural element including the information given in the operating instructions.



For that reason the guide must be read and understood before assembly. Safety devices need particular attention. Their perfect functioning is essential for a safe operation of the plant. As the safety devices are already preset at the factory their operations must be carried out immediately after the assembly itself. After monting the overspeed governer , the governor must be tested on the test groove. The functioning of safety switches on the governor and on the tension pulley must be checked. Aspar Asansör A.Ş is not responsible of the wrong assembled tension pulley.

#### 1.4 CHECK UPON RECEIPT

On receipt of the supply ,it is necessary to check the goods,by comparing each single part with the purchase order ,in order to verify their conformity and completeness.Do not use different weights and tension weights.

#### 1.5 LIST OF PARTS

The nominal speed data contained in the type-plate have to be compared with the order.  
List of parts :

1 pcs Overspeed governor - Fig. 2

1 pcs Tension Pulley Fig. 3

1 pcs Tension weight Fig. 4

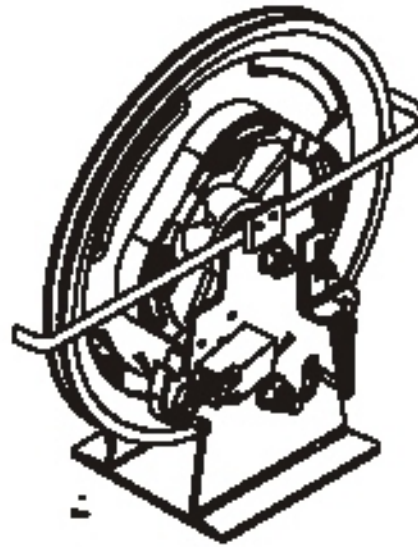

Fig. 2

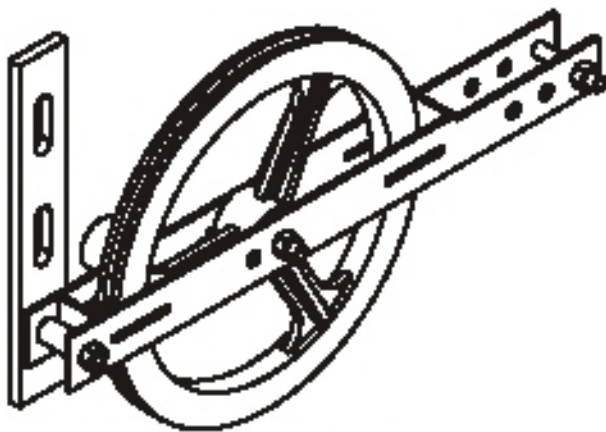

Fig. 3

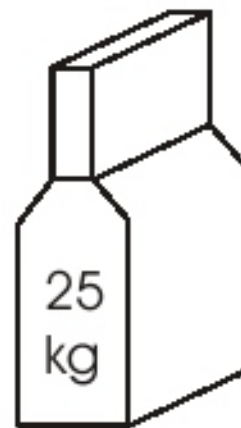

Fig.4



## 2-ASSEMBLY

For all the assembly works in the engine room or in elevator shaft ,it should be made clear below.



The entrance into the assembly area only for skilled and educated workers



During to assembly works,should use safety belts.



Cover the hole in the floor in the engine room. Secure the assembly tools and other objects to avoid falls. Engine room door must be locked and attach the appropriate warning signs on the elevator.

### 2.1 ASSEMBLY OF THE OVERSPEED GOVERNOR ON THE FLOOR

#### 2.1.1 ASSEMBLY IN THE ENGINE ROOM

The assembly of the overspeed governor can be performed directly on the floor or on a base.



Floor and support must resist to a pressure of min 20 kN



The passing openings of the rope should be kept as small as possible and must be fitted with safety rings 50 mm.

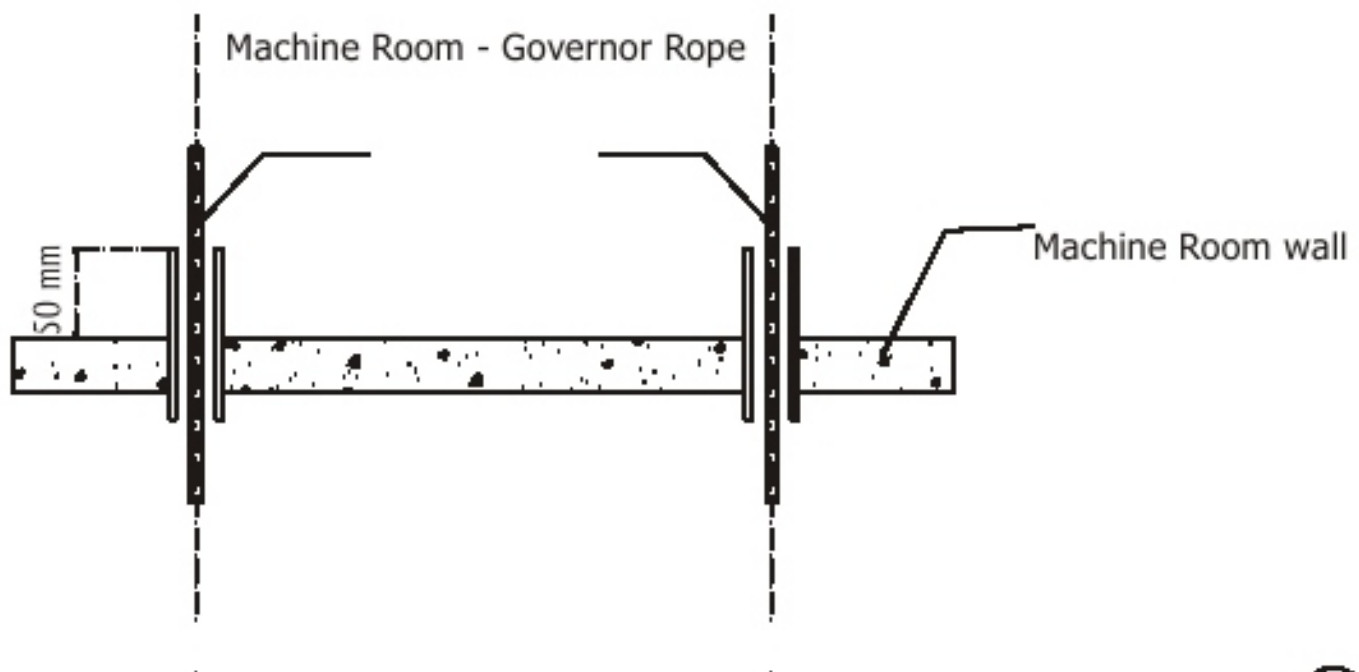

## 2.1.2 ASSEMBLY STEPS



You should assembly overspeed governor as shown the Figure 5.

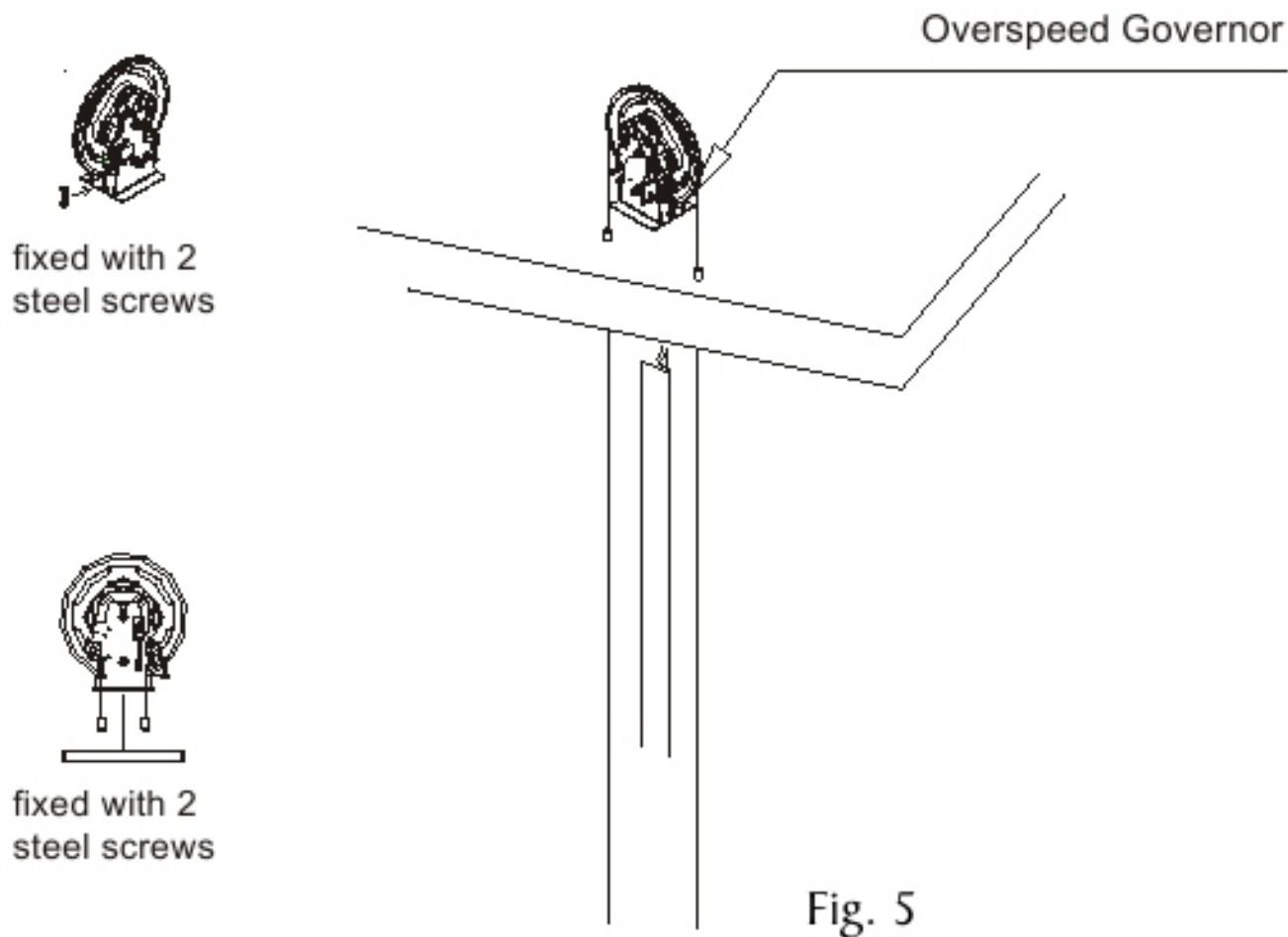

Through on an inspection door the overspeed governor must be easily accessible from outside in case of assembly in the elevator shaft.

## 2.1 ASSEMBLY OF THE ROPE OF THE OVERSPEED GOVERNOR AND TENSION PULLEY

A technically perfect operation of the overspeed governor is possible with a correct assembly of the governor rope itself and of the tension weight with counterweight.

While determining at which height the tension weight with counter weight has to be mounted it must be made clear that.

a- In no case, the counterweight must touch the floor. Figure 6.

b- When the cabinet presses hydraulic buffers rope anchors must never meet to tension pulley.

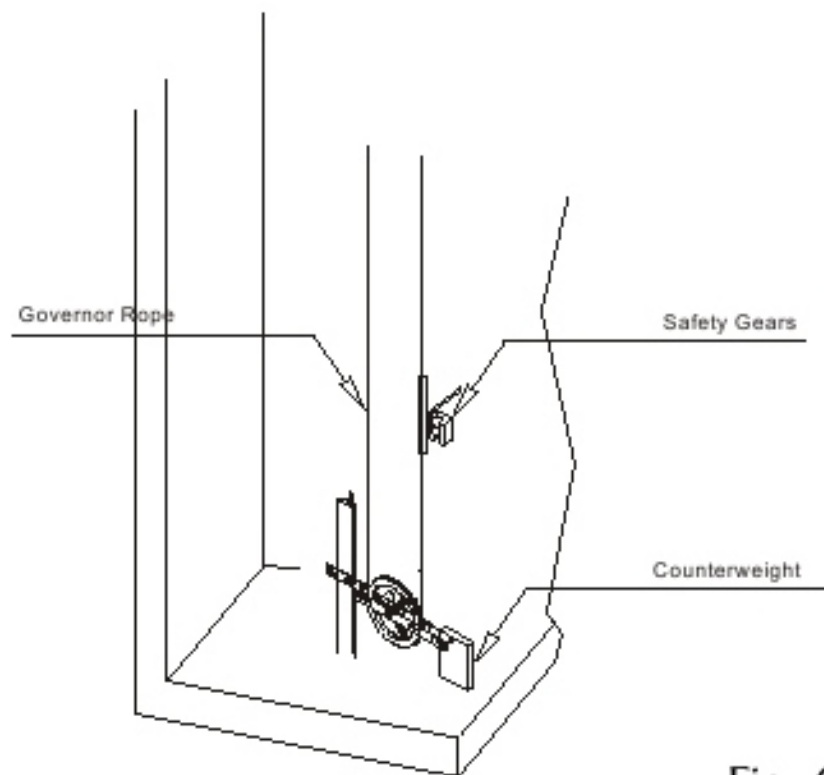

Fig. 6

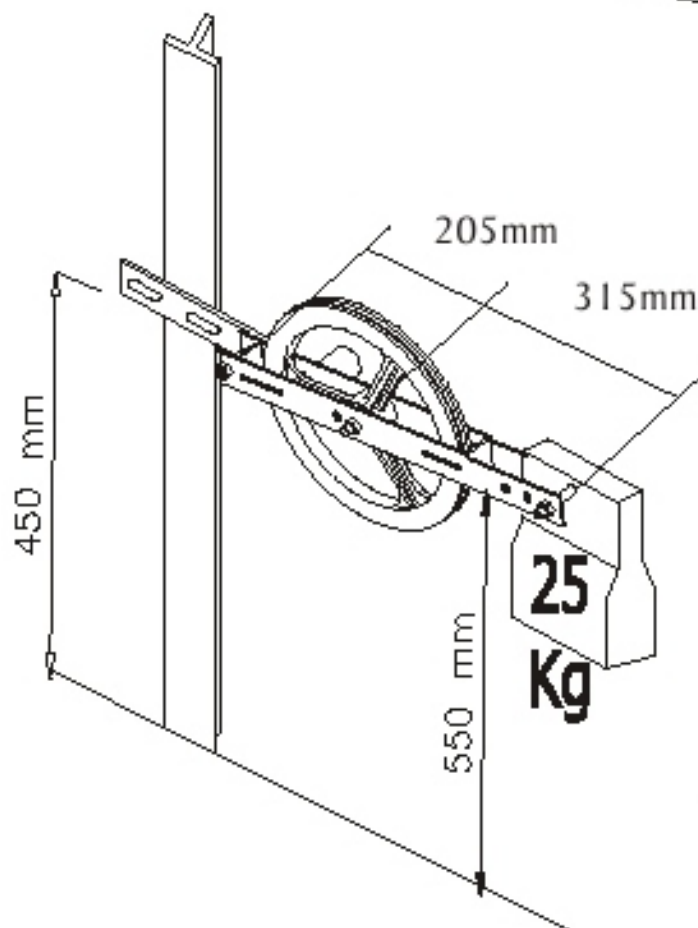

Fig. 7

Cut the overspeed governor rope sufficiently and lay it down on the rope pulley of the tension weight. Supply the first rope end with the rope anchor and attach it to the safety gear. Assemble the speed governor at about 450 mm on the bottom of the shaft. If the assembly has been correctly the angular measure will be 10. Figure 6.

## 2.3 ASSEMBLY OF THE SAFETY SWITCHES



All the works should be by specialized electricians,skilled workers



Before beginning operations,turn off the power of all the parts of the plant



All safety switch cables must be linked according to EMV rules and regulations.



Safety switches must be connected to safety circuit.

## 3. OPERATION TESTING

Although manufacturer tested product at the delivery before sale,eventually before the final test of the plant must be done.



Before performing the test, if necessary for safety gears the guide rails Should be oiled.

It is necessary to slowly run throught the whole are of action.Be sure that elevator works with out problem. At the lowest and highest level rope anchors should not meet the overspeed governor pulley and tension pulley. With a slow speed upwards and downwards ,operate by hand the overspeed governor.The safety switch must cut electricity connection.And check if safety gear works.Bring to overspeed governor,switch and brake device back again.

### TESTS ON NOMINAL SPEED ;

Follow indications below for test on declared speed:

Take the governer rope to test groove. When you take the rope to the test groove the tension pulley may cut off the safety circuit , check it. Alternative to the test groove the tests may be performed by forcing the catch pendulum by hand. At nominal speed the governor must block itself , brake off the safety circuit and activate the safety gears.After the elevator car stopped , first get the elevator car 20 mm up at the same time turn the governor pulley 20 mm opposite direction . Then safety switch must be positioned to its first place. Take the governor rope to original groove.

## 4-WARRANTY REGULATIONS and RESPONSIBILITY

According to EN81-1 and EN81-2 standards, ASRG 1.0 AND ASRG 1.6 is min 20 times locked under warranty. Also it has warranty for 2 years at declared regulation in the guide. Aspar Asansör A.Ş is not responsible of the damages in following situations.

- 1-If the component part is used in a different way than described in this guidebook.
- 2-Continue to use although the overspeed governor is damaged.
- 3-Not Used on purpose.
- 4-Changing the brake speed or removing the seal.
- 5-Changing any of the parts with another.
- 6-Not use on declared speed
- 7-Tension Pulley weight is heavier/lighter than declared weight in guide book.
- 8-Using damaged overspeed governors ,because of the disasters and external influences.

## 5-MAINTENANCE

ASRG 1.0 and ASRG 1.6 must be checked every 6 months and comments must be noted on Maintenance registration Form .

- 1-Check ropes if it is weared or stretched.
- 2-Check rope and safety gear connection points.
- 3-Check the grooves and tensioning pulley.  
Change the overspeed governor and tension pulley, if the distance between groove diameter on top and rope is more than 3 mm (when 6 mm governor rope is used).
- 4-Check clearance of the rope grooves.
- 5- Check the o-ring on the catch pendulum , change if deformed.
- 6-If overspeed governor rope is oily. It must be cleaned.



It is not allowed to operate the elevator plant even if temporarily, without the overspeed governor.



Only original spare parts must be mounted by the manufacturer. Never add any spare parts on it.